

## ENERGY SAVING MODEL DESIGN FOR SWING HYDRAULIC EXCAVATOR

Puja Chowdhury<sup>1,\*</sup>, Debdatta Das<sup>2</sup> and S. C. Banik<sup>3</sup>

<sup>1,2</sup>Graduate School of Mechanical Engineering, University of Ulsan,  
Namgu, Mugeodong 680-749 South Korea

<sup>3</sup>Department of Mechanical Engineering, Chittagong University of Engineering and Technology, Bangladesh.  
<sup>1,\*</sup>puja\_cuet08@yahoo.com, <sup>2</sup>debdattacuet@gmail.com, <sup>3</sup>baniksajal@yahoo.com

**Abstract**-Consuming rate of energy and pollution is more and more serious nowadays, so research on energy saving of hydraulic excavators has great interpretation because of their large application quantities, high energy consumption and bad exhaust. Among various possibilities, methods to recuperate energy during vehicle swing motion have been widely examined. The rotating movement of excavator is called swing or slew and is driven hydraulically. The swing drive is hence driven by a hydraulic motor creating a rotating motion. The proposed system is a closed system because bidirectional pump and motor are being used. In the swing braking time the remaining fluid will save as energy by a simple accumulator. In this purpose a newly designed, conventional swing system has been used. Proposed swing system have some dissimilarity from the original conventional swing system and more proficient. In the proposed system several type of relief valve, check vale and also hydraulic displacement valves will be used for saving more energy in the accumulator. Different simulation result with different parameter will show the change of proposed swing systems different criteria. The proposed system has been developed in AMESim software. This system will be more efficient in saving energy.

**Keywords:** Hydraulic Power, Swing System, Excavator, Accumulator, Save Energy.

### 1. INTRODUCTION

Depending on the “energy crisis”, the demand for more environmental and fuel efficient construction machinery, especially for hydraulic excavator, has been increased in response for growing concerns on the clean environment and saving energy [1]. Applying the electric hybrid technique on the off-road vehicle is one popular method to reduce the fuel consumption [2]. Consequently, many researches on design and control of hybrid systems applied to hybrid electric vehicles have been done [3-4]. For different type of civil engineering construction works like level digging or flat surface finishing work such as preparing housing foundations, reclamation of paddy fields or pipe laying, hydraulic excavator has performed an essential task [5]. For the reduction of excavator fuel consumption, various energy recovery methods have been studied extensively [6]. Energy recuperation methods during excavator boom down or swing deceleration show great potential in improving fuel efficiency [7-13]. Beyond energy recovery, full parallel hybrid systems have also been examined and have shown to greatly improve efficiency [7-10, 14]. The rotating movement of the hydraulic excavator is called swing or slew and is driven hydraulically [15]. In conventional swing system the energy recovery rate is not up to mark. In 1992 a patent application was accepted from Mannesmann Rexroth for the combination of an electrical tachometer and an electrical swivel angle feedback. As designed, the secondary control principle was consequently protected for the company until the year 2000 [16]. A Figure of a hydraulic excavator with

swing system is given in Fig 1.



Fig. 1 Hydraulic excavator

In 2003, Hitachi launches the first electric hybrid wheel loader. Later, Kobelco introduced another series of the hybrid excavator which is using engine to drive the generator and supply four subsystems [17].

The main problems for the electric hybrid off-road vehicles are not popularly used in the market because of the different working conditions between them and the high cost of on-road ones. Moreover, it is difficult to recover the potential energy of the linear load [18]. Later, Kobelco introduced another series of the hybrid excavator which is using engine to drive the generator and supply four subsystems [17]. In this paper a new modified method of energy recovery in conventional

swing system is being proposed. The proposed system is also a closed system because bidirectional pump and motor are being used. In the swing braking time the remaining fluid will save as energy by a simple accumulator. This remaining save energy will use in the system from accumulator. In this purpose conventional swing system will be used. Because of the dissimilarity with original conventional swing system, the proposed system has made more proficient. In the proposed system several type of relief valve, check vale and also hydraulic displacement valves will be used for saving more energy in the accumulator. From the system, try to save energy with different simulation result by using different parameter. This system will be more efficient in saving energy.

## 2. STRUCTURE OF THE PROPOSEDSWING SYSTEM

A new modified method of energy recovery in

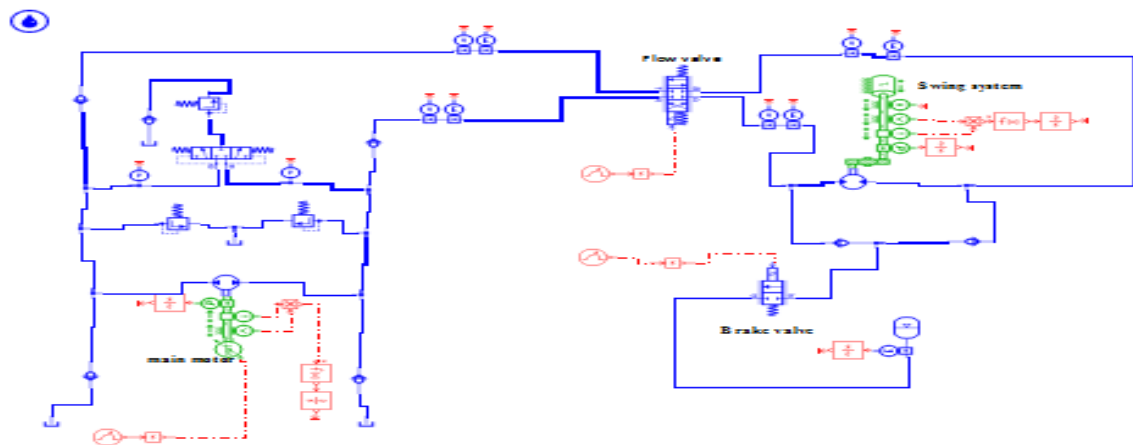

Fig 2: The AMESim circuit of the proposed swing system

The swing drive is driven by a gearbox with an attached bi-directional hydraulic motor. Only for saving energy in the brake time the brake valve will open. Moreover brake control valve is setup in parallel with the hydraulic motor to adjust the flow rate going to the accumulator. By the help of two check valves, remaining fluid at first come to brake valve and finally save in the accumulator as energy. Dimensions of the system are given below in Table 1 and Table 2.

Table 1: Dimensions for the proposed swing system

Component	Value	Unit
Gear ratio	200	.....
Motor Displacement	35.5	cc/rev
Motor Speed	1000	rev/min
Pump Displacement	75	cc/rev
Pump Speed	1000	rev/min

conventional swing system is being proposed. The effect of accumulator capacity with different parameter, in a novel conventional swing for hydraulic excavator with higher working efficiency and energy saving ability, is proposed in this research. It is the combination of hybrid electro-hydraulic actuators with swing system. The electric motor drive the hydraulic pump directly. The swing system is controlled with an electric motor and a bi-directional hydraulic pump after following the given working commands. Basically there are two displacement position of swing drive. Following the movement of a joystick, the pump is controlled to match the spool positions, swiveling out. One is the positive displacement and the other is the reverse movement from the positive displacement. Flow from the pump passes through the flow valve and come to the motor which directly drive the swing system. The AMESim circuit of the proposed system is displayed in Fig. 2.

Accumulator gas precharge pressure	100	bar
Accumulator volume	20-100	L

Table 2: Dimensions for the Swing model

Component	Value	Unit
Moment of inertia	102000	kgm <sup>2</sup>
Viscous Friction	600	Nm/(rev/min)
Coulomb Friction	3300	Nm
Static Friction	3500	Nm

In one working cycle of the proposed secondary swing system there are six different steps and each step duration is different. Two main steps are positive and reverse displacement. After each positive and after each reverse step there are one brake and one steady state step.

### 3. SIMULATION AND RESULT

Depending on the working condition of the proposed swing system for hydraulic excavator, the capacity of the accumulator will be tuned and following the input signal by the movement of joystick and try to obtain the maximum saving energy. Swing system angular displacement is shown in Fig.3.

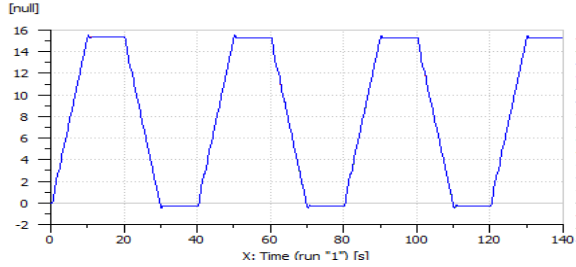

Fig.3: Swing angular displace

In this section, a series of simulation and results are carried out to evaluate the effectiveness of the proposed secondary control swing for hydraulic excavator system. Swing shaft speed is shown in Fig.4.

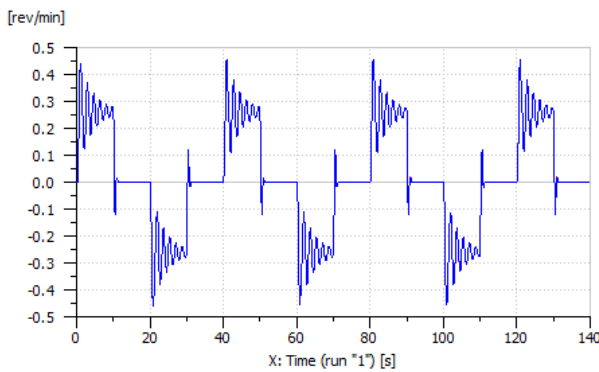

Fig.4: Swing shaft speed

Here the capacity of accumulator is changed from 20L to 100L. Fig.5 show the input energy of the system. Swing system used power and accumulator save energy are shown in Fig.6 and Fig.7.

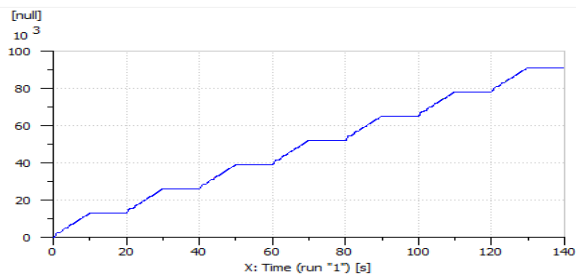

Fig. 5: Input Power of the electric motor.

The output of the simulation results, show that the proposed swing system for hydraulic excavator has energy saving capability. Simulation results are depicted in Table.3 with the variation of accumulator capacity.

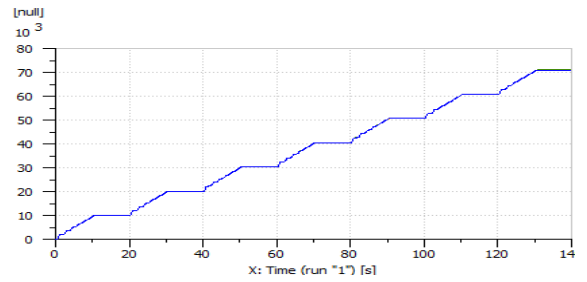

Fig.6: Swing used power

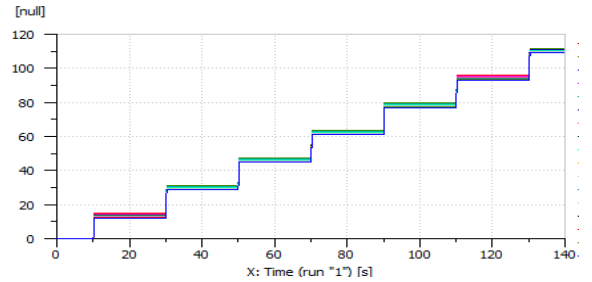

Fig.7: Save energy in the accumulator

Table 3: Simulation results

Accumulator volume(L)	Input power (watt)	Swing used power (watt)	Accumulator Consume energy (watt)
20	91242.17	71014.05	111.6648
25	91246.21	71023.64	111.5191
30	91239.74	71008.81	111.2679
35	91236.73	71002.13	111.0522
40	91243.73	71016.93	111.0016
45	91241.28	71011.12	110.8031
50	91241.44	71010.91	110.6567
55	91237.03	71000.61	110.4545
60	91244.33	71016.8	110.3814
65	91230.08	70985.12	110.072
70	91237.02	71000.07	109.9747
75	91244.73	71015.55	109.9676
80	91238.06	71000.31	109.7443
85	91233.23	70990.92	109.4907
90	91235.88	70996.49	109.393
95	91244.68	71015.15	109.3606
100	91233.53	70990.72	109.059

### 4. CONCLUSIONS

A newly designed swing conventional system for hydraulic excavator with a suitable control strategy is proposed in this paper. The concepts of the energy saving based on the accumulator system and simulated by AMESim software. The effect of accumulator capacity is analyzed for the proposed system. As a result, by increasing the accumulator capacity the amount of save energy is increased. But from a series of simulation, an optimum value of moment of inertia with various accumulator capacity, the level of save energy is still not up to mark. But the proposed system is able for saving energy then the original conventional swing system. It is

expected that the experimental study by using the control strategies of the proposed swing system for hydraulic excavator will be performed more efficiently. To utilize the store energy in future, combination of transformer will help to allow the stored fluid flow back into the system.

## 5. REFERENCES

- [1] T. Lin, Q. Wang, B. Hu, and W. Gong, "Research on the energy regeneration systems for hybrid hydraulic excavators", *Automation in Construction*, vol. 19, pp. 1016-1026, 2010.
- [2] W. Shen, J. Jiang, X. Su, and H. R. Karimi, "Control strategy analysis of the hydraulic hybrid excavator", *Journal of the Franklin Institute*, vol. 352, pp. 541-561, 2015.
- [3] Z. Han, Z. Yuan, T. Guangyu, C. Quanshi, and C. Yaobin, "Optimal Energy Management Strategy for Hybrid Electric Vehicles", *SAE International Technical Paper*, vol. 113, no. 3, pp. 408-417, 2004.
- [4] N. Schouten, M. Salman, and N. Kheir, "Fuzzy Logic Control for Parallel Hybrid Vehicles", *IEEE Transactions on Control Systems Technology*, vol. 10, no. 3, 2002.
- [5] M. Haga, W. Hiroshi, and K. Fujishima, "Digging control system for hydraulic excavator", *Mechatronics*, vol. 11, pp. 665-676, 2001.
- [6] B. Thompson, H. Yoon, J. Kim, and J. Lee, "Swing Energy Recuperation Scheme for Hydraulic Excavators", *SAE International Technical Paper*, 2014.
- [7] D. Wang, C. Guan, S. Pan, M. Zhang, and X. Lin, "Performance analysis of hydraulic excavator powertrain hybridization", *Automation in Construction*, vol 18, pp. 248-257, 2009.
- [8] T. Lin, Q. Wang, B. Hu, and W. Gong, "Development of hybrid powered hydraulic construction machinery", *Automation in Construction*, vol. 19, pp. 11-19, 2010.
- [9] T. Lin, Q. Wang, B. Hu, and W. Gong, "Research on the energy regeneration systems for hybrid hydraulic excavators", *Automation in Construction*, vol.19, pp. 1016-1026, 2010.
- [10] T. Kwon, S. Lee, S. Sul, C. Park, N. Kim, B. Kang, and M. Hong, "Power Control Algorithm for Hybrid Excavator with Super capacitor", *IEEE Transactions on Industry Applications*, vol. 46, no. 4, 2010.
- [11] A. Pourmovahed, N. H. Beachley, and F. J. Fronczak, "Modeling of a Hydraulic Energy Regeneration System: Part I—Analytical Treatment", *Journal of Dynamic Systems, Measurement, and Control*, vol. 114, 1992.
- [12] T. Ho, and K. Ahn, "Design and control of a closed-loop hydraulic energy-regenerative system," *Automation in Construction*, vol 22, pp. 444-458, 2012.
- [13] R. Hippalgaonkar, J. Zimmerman, and Monika Ivantysynova, "Investigation of Power Management Strategies for a Multi-Actuator Hydraulic Hybrid Machine System", *SAE International Technical Paper*, 2011.
- [14] X. LIN, S. PAN, and D. WANG, "Dynamic simulation and optimal control strategy for a parallel hybrid hydraulic excavator", *Journal of Zhejiang University SCIENCE*, 2008.
- [15] K. Pettersson, *Secondary Controlled Swing Drive*, Master Thesis, Linköping University, 2008.
- [16] R. Kordak, *Hydrostatic Drives with Control of the Secondary Unit, Mannesmann Rexroth*, vol.6, 1996.
- [17] M. Kagoshima, M. Komiyama, T. Nanjo, and A. Tsutsui, "Development of New Hybrid Excavator", *KOBELCO Technology Review*, no. 27, 2007.
- [18] J. Nyman, J. Bärnström, K. Rydberg, "Use of accumulators to reduce the need of electric power in hydraulic lifting systems", *Scandinavian International Conference on Fluid Power, SICFP03*, 2004.